

AP
ANSELMIPORTE

Unica come te.

Catalogo generale
General catalogue
Общий каталог



Perché ci mettiamo il cuore, per regalarvi qualcosa di ECCEZIONALE.

Because we put our heart, to give you something of EXCEPTIONAL.

Мы всем сердцем предлагаем Вам абсолютно уникальный продукт.





Stile, classe ed eleganza si fondono insieme a qualità e rispetto per la natura: queste sono le creazioni ANSELMI. Prodotti destinati ad arredare con classe i vostri ambienti, che daranno quel tocco di UNICITÀ alla vostra casa. Dai nostri prodotti traspare tutto il nostro impegno, tutta la nostra dedizione e tutto l'amore per il nostro lavoro.

Style, class and elegance together with quality and respect for nature: these are the Anselmi creations. Products designed to decorate your rooms with charm, that will give a touch of uniqueness to your home. From our product shine through all our efforts, our devotion and the love for our work.

Стиль, элегантность, высочайшее качество и бережное отношение к природе - это базовые понятия фабрики ANSELMI. Продукция, предназначенная для рафинированного украшения Вашего дома, придающая шарм уникальности. В производимые нами двери мы в полной мере вкладываем все наши умения, старания, стремления, нашу преданность любимому делу.



L'ARTE DELLA FALEGNAMERIA TRAMANDATA DI GENERAZIONE IN GENERAZIONE

LA FAMIGLIA ANSELMI si tramanda l'arte della falegnameria di alto livello da generazioni. Nel 1962 Raul fonda l'azienda, diventando negli anni un riferimento per la produzione di arredamento a livello locale. Ma è con l'entrata del figlio Giuseppe che l'azienda viene portata ai massimi livelli, iniziando poi nel 2003 la produzione di porte in massello di pregio a livello nazionale. Dal 2009 Francesca affianca il padre Giuseppe nella gestione dell'azienda, e portano l'azienda sempre verso nuovi obiettivi.



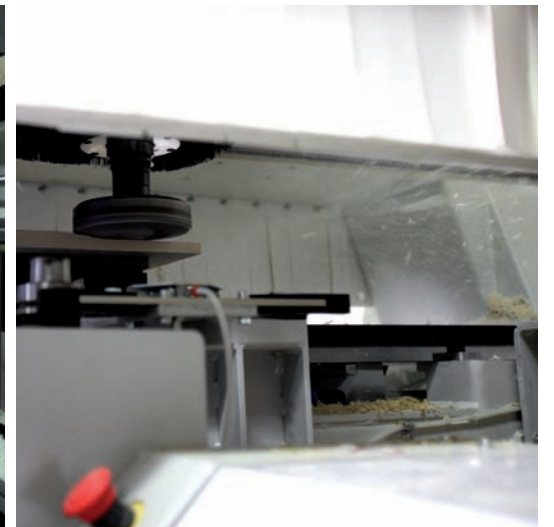

THE ART OF THE WOODWORKING PASSED DOWN FROM GENERATION TO GENERATION

Anselmi's family has passed down the art of high level woodworking for generations. Raul founded the company in 1962, over the years becoming a reference for the local production of furniture. However it is only with the entry of his son Giuseppe that the company has taken at the highest levels, starting the national production of precious solid wood doors in 2003. Since 2009, Francesca joined his father Giuseppe in the company's management and lead the company to new goals.

ИСКУССТВА ИЗ ДЕРЕВА ПЕРЕДАВАЛИСЬ ИЗ ПОКОЛЕНИЯ В ПОКОЛЕНИЕ

Семья Ансельми передает высочайший уровень столярного мастерства уже на протяжении трех поколений. Рауль Ансельми основал компанию в 1962 год, став за последующие годы лучшим в производстве мебели на региональном уровне. Но с вступлением его сына Иосифа, компания ставит перед собой цель активного развития и совершенствования. Начиная с 2003 года предприятие, производящие элитные двери из массива дерева, приобретает признание национальном уровне. С 2009 года и дочь Иосифа - Франческа присоединяется к семейному бизнесу, активно участвуя в управлении компании. Любовь и преданность своему делу сплачивает нашу команду.





SCEGLIERE ANSELMI VUOL DIRE ANCHE AMARE LA NATURA

LA NOSTRA ANIMA ECOLOGISTA fa sì che il rispetto per l'ambiente sia al primo posto; le nostre porte sono prodotte con legnami provenienti da deforestazione controllata ed usiamo solo ed esclusivamente vernici ECOLOGICHE all'acqua, che non rilasciano solventi nell'ambiente. Una scelta d'AMORE PER LA NATURA, ma anche per i nostri dipendenti.

SELECT ANSELMI ALSO MEANS LOVING NATURE

Our ECOLOGIST SPIRIT put the respect for the environment in first place. For this reason our doors are manufactured with wood originated from regulated deforestation, using only ecological water paints, in this way solvents are not release into the environment. A choice of LOVE FOR NATURE, but also for our employees.

ВЫБОР ФАБРИКИ ANSELMИ - ЭТО ЗАБОТА О НАШЕМ БУДУЩЕМ, ОБ ОКРУЖАЮЩЕЙ ПРИРОДЕ

Приоритетным направлением деятельности нашей фабрики – является Уважение и Забота об окружающей среде. Двери изготавливаются из сырья высшего качества, тщательно отобранного и выдержанного натурального дерева и эссенций, поступающего только из экологических питомников с контролируемой вырубкой, что позволяет гармонично восстанавливать лесные насаждения. Мы применяем исключительно экологические красители на водяной основе, абсолютно не загрязняющие окружающую среду. Все отходы производства либо реутилизируются для изготовления древесной пасты, либо поставляются аграриям. Выбор нашего коллектива – созидание и гармония с природой!



THE RESEARCH FOR PERFECTION IN QUALITY AND STYLE

The TECHNICAL EVOLUTION AND THE RESEARCH for the stylistic improvement has been continuous, leading us to create a very high quality standards product. Anyway this was not enough: our products, in addition to being high quality, has to be refined, sumptuous, elegant. Products are created for sophisticated spaces, elegant, REFINED. It is how were born our two pearls, the collections Intarsie and Luxury, the last two chapters of a success story. Years and years of experience to bring to your space a charming and shining element.



LA RICERCA DELLA PERFEZIONE QUALITATIVA E STILISTICA

L'EVOLUZIONE E LA RICERCA del miglioramento tecnico e stilistico è stata continua, portandoci a realizzare un prodotto dagli standard qualitativi altissimi. Ma questo non ci è bastato: i nostri prodotti, oltre ad essere qualitativamente superiori, dovevano essere raffinati, sontuosi, ELEGANTI. Creati per ambienti sofisticati, signorili, RICERCATI. Ed è così che sono nate le nostre due perle, le collezioni Intarsie e Luxury, ultimi due capitoli di una storia di successi. Anni e anni di esperienza per portare nei vostri ambienti un elemento che parla di fascino e splendore.

ПОСТОЯННОЕ СОВЕРШЕНСТВОВАНИЕ КАЧЕСТВА И ПОИСК НОВЫХ СТИЛИСТИЧЕСКИХ РЕШЕНИЙ

Предприятие постоянно совершенствуется технически, разрабатываются новые стилистические решения. Мы стремимся к созданию продукта, соответствующего самым высоким требованиям. Для нас недостаточно просто радовать Вас отличным качеством, мы хотели бы предоставить широкую гамму изысканных, роскошных, элегантных моделей, способных создавать благородную комфортную обстановку уюта в Вашем доме. Так зародились наши две жемчужины, коллекции Intarsie и Luxury - последние две главы в нашей истории успеха. Годы и годы опыта потребовались, чтобы предложить Вашему интерьеру элементы, очаровывающие и поражающие великолепием.



SCEGLIERE UNA PORTA ANSELMI SIGNIFICA SCEGLIERE UN PRODOTTO UNICO!

Non solo per la possibilità di personalizzazione, ma perché ogni decoro, ogni intarsio, ogni incisione è realizzata a mano da maestri artigiani, che creeranno per voi un prodotto IRRIPETIBILE. Un segno distintivo per la vostra abitazione.

CHOOSE A DOOR ANSELMI MEANS DECIDING ON A UNIQUE PRODUCT!

It is not only for the possibility of customization, but because each ornament, inlay and engraving are handmade by master craftsmen, who will create for you a unique product and a distinctive sign for your home.

ВЫБОР ДВЕРЕЙ ANSELMИ ОЗНАЧАЕТ ВЫБОР УНИКАЛЬНОГО ПРОДУКТА!

Мы готовы не только персонализировать выбранные Вами модели на высочайшем уровне (это будут эксклюзивные, специально только для Вас созданные двери), но и хотели бы подчеркнуть, что любой резной декор, каждое интарсио, каждая роспись - выполняется мастерами вручную. Мы предлагаем Вам единственный, уникальный, в своем роде, продукт.



Indice / Contents / Индекс

LUXURY	08
<i>Luxury</i> - Роскошные	
INTARSIE	56
<i>Inlays</i> - Инкрустированные	
ANTICATE	64
<i>Distressed</i> - С Эффектом Антикатуры	
CLASSICHE	78
<i>Classical</i> - Классические	
MODERNE	96
<i>Modern</i> - Современные	
ACCESSORI	110
<i>Accessories</i> - ДЕТАЛИ	
ESSENZE	118
<i>Wood essences</i> - Древесных пород	
FINITURE	120
<i>Finishes</i> - Отделка	
MODELLI PORTE	124
<i>Door models</i> - Модели дверей	
AREA TECNICA	126
<i>Technical area</i> - Технические области	

LUXURY

Luxury - РОСКОШНЫЕ

08 |

CORNICI PERFETTE e atmosfere lussuose dedicate a te. Alleanza tra teoria e pratica per dare forma alle idee. L'incontro tra innovazione tecnologica e maestri artigiani garantisce risultati sorprendenti. Un incessante *work in progress*, dove «a dare carattere agli ambienti, nonostante la loro evoluzione continua, sono le porte dal forte impatto stilistico».

PERFECT FRAMES and luxury atmospheres designed for you. Theory and practice come together to shape ideas. The encounter between technological innovation and craftsmen ensures amazing results. A constant work in progress, where "doors with a strong impact in terms of style add character to environments, despite their constant evolution".

ИДЕАЛЬНЫЕ РАМЫ и роскошная атмосфера только для Вас. Теория и практика объединяются, чтобы придать форму идее. Встреча технологических инноваций с мастерами ремесленного искусства гарантирует удивительные результаты. Непрерывная *work in progress*, где "несмотря на постоянное развитие дизайна интерьера, характер помещению придают высокостилизованные двери."







ROMA

Luxury - Luxury - РОСКОШНЫЕ

11



ESSENZA
Essence
Сущность

FINITURA
Finish
Отделка

VERSIONE
Version
Версия

ACCESSORI
Accessories
Аксессуары

MANIGLIA
Handle
Ручка

TOULIPIER

LACCATO PENNELLATO EST.112 - INT. 100
ANTICATURA A SPUGNA - FOGLIA ORO

BATTENTE

COPRIFILO BAROCCO DA 100

LUIGI XVI C05110
ORO

FIRENZE

Luxury - Luxury - РОСКОШНЫЕ

12 |



ESSENZA
Essence
Сущность

FINITURA
Finish
Отделка

VERSIONE
Version
Версия

ACCESSORI
Accessories
Аксессуары

MANIGLIA
Handle
Ручка

TOULIPIER

LACCATO PENNELLATO EST.112 - INT.100
ANTICATURA A SPUGNA - FOGLIA ORO

BATTENTE

COPRIFILO BAROCCO DA 100

EPOCA
OTTONE ANTICATO



FINITURA: LACCATO PENNELLATO ESTERNO 112 - INTERNO 100 - ANTICATURA A SPUGNA - FOGLIA ORO.

Finish: brushed lacquered outside 112 - inside 100 - Sponge antiquing - Golden leaf.

Отделка: лакировка и окраска снаружи 112 - внутри 100 - Антикатура губкой - Фольгирование золотом.

FINITURA: LACCATO
PENNELLATO ESTERNO 119 -
INTERNO 100 - ANTICATURA
A SPUGNA - FOGLIA ARGENTO.
*Finish: brushed lacquered outside 119 -
inside 100 - Sponge antiquing -
Silver leaf.*

Отделка: лакировка и окраска
снаружи 119 - внутри 100 -
Антикатура губкой -
Фольгирование серебром.



PARIGI

Luxury - Luxury - РОСКОШНЫЕ

| 15



ESSENZA
Essence
Сущность

FINITURA
Finish
Отделка

VERSIONE
Version
Версия

ACCESSORI
Accessories
Аксессуары

MANIGLIA
Handle
Ручка

TOULIPIER

LACCATO PENNELLATO - EST.119 - INT.100
ANTICATURA A SPUGNA - FOGLIA ARGENTO

BATTENTE

COPRIFILO BAROCCO DA 100

LUIGI XV - C12810
ORO



MADRID

Luxury - Luxury - РОСКОШНЫЕ

| 17



ESSENZA
Essence
Сущность

FINITURA
Finish
Отделка

VERSIONE
Version
Версия

ACCESSORI
Accessories
Аксессуары

MANIGLIA
Handle
Ручка

TOULIPIER

LACCATO PENNELLATO EST.204 - INT.100
ANTICATURA A SPUGNA - FOGLIA ORO

BATTENTE

CAPITELLO TIPO 2

MANIERISMO C01215 -
ORO

PRAGA

Luxury - Luxury - РОСКОШНЫЕ

18 |



ESSENZA
Essence
Сущность

FINITURA
Finish
Отделка

VERSIONE
Version
Версия

ACCESSORI
Accessories
Аксессуары

MANIGLIA
Handle
Ручка

TOULIPIER

LACCATO PENNELLATO - EST.112 - INT.100
ANTICATURA A SPUGNA - FOGLIA ORO

BATTENTE

COPRIFILO BAROCCO DA 100

PRIMO IMPERO C11011
ORO



FINITURA: LACCATO PENNELLATO
ESTERNO 112 - INTERNO 100 -
ANTICATURA A SPUGNA - FOGLIA ORO.
*Finish: brushed lacquered outside 112 - inside
100 - Sponge antiquing - Golden leaf.*
Отделка: лакировка и окраска снаружи
112 - внутри 100 - Антикатура губкой -
Фольгирование золотом.



FINITURA: LACCATO PENNELLATO ESTERNO 123 -
INTERNO 112 - ANTICATURA A SPUGNA.

*Finish: brushed lacquered outside 123 - inside 112 -
Sponge antiquing.*

Отделка: лакировка и окраска снаружи 123 -
внутри 112 - Антикатура губкой.

VARSAVIA

Luxury - Luxury - РОСКОШНЫЕ

| 21



ESSENZA
Essence
Сущность

FINITURA
Finish
Отделка

VERSIONE
Version
Версия

ACCESSORI
Accessories
Аксессуары

MANIGLIA
Handle
Ручка

TOULIPIER

LACCATO PENNELLATO EST.123 - INT.112
ANTICATURA A SPUGNA

BATTENTE

COPRIFILO BAROCCO DA 100

GINEVRA
BRONZO GRAFFIATO



LONDRA

Luxury - Luxury - РОСКОШНЫЕ

| 23



ESSENZA
Essence
Сущность

FINITURA
Finish
Отделка

VERSIONE
Version
Версия

ACCESSORI
Accessories
Аксессуары

MANIGLIA
Handle
Ручка

TOULIPIER

LACCATO PENNELLATO
EST.190 SCHIARITO INT.204 SCHIARITO
ANTICATURA A SPUGNA - FOGLIA ARGENTO

BATTENTE

CAPITELLO TIPO 2

PRIMO IMPERO C12512
CROMO

SOFIA

Luxury - Luxury - РОСКОШНЫЕ

24 |



ESSENZA
Essence
Сущность

FINITURA
Finish
Отделка

VERSIONE
Version
Версия

ACCESSORI
Accessories
Аксессуары

MANIGLIA
Handle
Ручка

TOULIPIER

LACCATO PENNELLATO EST.123 - INT.100
ANTICATURA A SPUGNA

BATTENTE

CAPITELLO TIPO 2

GINEVRA
BRONZO GRAFFIATO



FINITURA: LACCATO PENNELLATO
ESTERNO 123 - INTERNO 100 -
ANTICATURA A SPUGNA.
*Finish: brushed lacquered outside 123 -
inside 100 - Sponge antiquing.*
Отделка: лакировка и окраска снаружи
123 - внутри 100 - Антикатура губкой.

FINITURA: LACCATO
PENNELATO COLORE 177.
Finish: brushed lacquered 177.
Отделка: лакировка и
окраска 177.



BERNA

Luxury - Luxury - РОСКОШНЫЕ

| 27



ESSENZA
Essence
Сущность

FINITURA
Finish
Отделка

VERSIONE
Version
Версия

ACCESSORI
Accessories
Аксессуары

MANIGLIA
Handle
Ручка

TOULIPIER

LACCATO PENNELLATO
COLORE 177

BATTENTE

CAPITELLO TIPO 2

PRIMO IMPERO C12512
CROMO



VIENNA

Luxury - Luxury - РОСКОШНЫЕ

| 29



ESSENZA
Essence
Сущность

FINITURA
Finish
Отделка

VERSIONE
Version
Версия

ACCESSORI
Accessories
Аксессуары

MANIGLIA
Handle
Ручка

TOULIPIER

LACCATO PENNELLATO EST.112 - INT.100
ANTICATURA A SPUGNA - FOGLIA ARGENTO

BATTENTE

COPRIFILO BAROCCO DA 100

PRIMO IMPERO C12512
CROMO

SAN PIETROBURGO

Luxury - Luxury - РОСКОШНЫЕ

30 |



ESSENZA
Essence
Сущность

FINITURA
Finish
Отделка

VERSIONE
Version
Версия

ACCESSORI
Accessories
Аксессуары

MANIGLIA
Handle
Ручка

TOULIPIER

LACCATO PENNELLATO EST.119 - INT.100
ANTICATURA A SPUGNA - FOGLIA ORO

BATTENTE

CAPITELLO TIPO 2

MANIERISMO C01210
ORO



FINITURA: LACCATO PENNELLATO
ESTERNO 119 - INTERNO 100 -
ANTICATURA A SPUGNA - FOGLIA ORO.
*Finish: brushed lacquered outside 119 - inside
100 - Sponge antiquing - Golden leaf.*
Отделка: лакировка и окраска снаружи
119 - внутри 100 - Антикатура губкой -
Фольгирование золотом.

FINITURA: LACCATO
PENNELATO ESTERNO 112 -
INTERNO 100 - ANTICATURA A
SPUGNA - DISEGNO FOGLIA ORO.
*Finish: brushed lacquered outside 112
- inside 100 - Sponge antiquing -
Golden leaf design.*

Отделка: лакировка и окраска
снаружи 112 - внутри 100 -
Антикатура губкой - Рисунок
фольгирование золотом.



VENEZIA

Luxury - Luxury - РОСКОШНЫЕ

33



ESSENZA
Essence
Сущность

FINITURA
Finish
Отделка

VERSIONE
Version
Версия

ACCESSORI
Accessories
Аксессуары

MANIGLIA
Handle
Ручка

TOULIPIER

LACCATO PENNELLATO EST.112 - INT.100
ANTICATURA SPUGNA - DISEGNO FOGLIA ORO

BATTENTE

COPRIFILO BAROCCO DA 100

LUIGI XV C12810
ORO



ANASTASIA

Luxury - Luxury - РОСКОШНЫЕ

| 35



ESSENZA
Essence
Сущность

FINITURA
Finish
Отделка

VERSIONE
Version
Версия

ACCESSORI
Accessories
Аксессуары

MANIGLIA
Handle
Ручка

TOULIPIER

LACCATO PENNELLATO - EST.112
INTERNO BUGNA VERDE ANTICO - FOGLIA ORO

BATTENTE

CAPITELLO TIPO 2

LUIGI XVI C05110
ORO

BUDAPEST

Luxury - Luxury - РОСКОШНЫЕ

36 |



ESSENZA
Essence
Сущность

FINITURA
Finish
Отделка

VERSIONE
Version
Версия

ACCESSORI
Accessories
Аксессуары

MANIGLIA
Handle
Ручка

TOULIPIER

LACCATO PENNELLATO EST.112
INT.190 SCHIARITO - ANTICATURA SPUGNA

BATTENTE

COPRIFILO BAROCCO DA 100

RITA
ARGENTO VECCHIO



FINITURA: LACCATO PENNELLATO ESTERNO 112 - INTERNO 190 SCHIARITO - ANTICATURA A SPUGNA - FOGLIA ARGENTO.
Finish: brushed lacquered outside 112 - lightened inside 190 - Sponge antiquing - Silver leaf.
Отделка: лакировка и окраска снаружи 112 - внутри 190 осветлен - Антикатура губкой - Фольгирование золотом.



STOCCOLMA

Luxury - Luxury - РОСКОШНЫЕ

| 39



ESSENZA
Essence
Сущность

FINITURA
Finish
Отделка

VERSIONE
Version
Версия

ACCESSORI
Accessories
Аксессуары

MANIGLIA
Handle
Ручка

TOULIPIER

LACCATO PENNELLATO EST.208 - INT.100
ANTICATURA A SPUGNA - FOGLIA ORO

BATTENTE

COPRIFILO BAROCCO DA 100

MANIERISMO C01210
ORO



FINITURA: LACCATO PENNELLATO
ESTERNO 119 - INTERNO 107 -
ANTICATURA A SPUGNA.
*Finish: brushed lacquered outside 119 -
inside 107 - Sponge antiquing.*
Отделка: лакировка и окраска
снаружи 119 - внутри 107 -
Антикатура губкой.

COPENAGHEN

Luxury - Luxury - РОСКОШНЫЕ

| 41



ESSENZA
Essence
Сущность

FINITURA
Finish
Отделка

VERSIONE
Version
Версия

ACCESSORI
Accessories
Аксессуары

MANIGLIA
Handle
Ручка

TOULIPIER

LACCATO PENNELLATO - EST.119 - INT.107
ANTICATURA A SPUGNA

BATTENTE

CAPITELLO TIPO 2

CHARME
OTTONE ANTICATO

BORDEAUX

Luxury - Luxury - РОСКОШНЫЕ

42 |



ESSENZA
Essence
Сущность

FINITURA
Finish
Отделка

VERSIONE
Version
Версия

ACCESSORI
Accessories
Аксессуары

MANIGLIA
Handle
Ручка

TOULIPIER

LACCATO PENNELLATO EST.204 - INT.112
ANTICATURA A SPUGNA - FOGLIA ORO

BATTENTE

CAPITELLO TIPO 2

ROMEA
OTTONE ANTICATO



FINITURA: LACCATO PENNELLATO ESTERNO 204 - INTERNO 112 - ANTICATURA A SPUGNA - FOGLIA ORO.

Finish: brushed lacquered outside 204 - inside 112 - Sponge antiquing - Golden leaf.

Отделка: лакировка и окраска снаружи 204 - внутри 112 - Антикатура губкой - Фольгирование золотом.



BARCELLONA

Luxury - Luxury - РОСКОШНЫЕ

| 45



ESSENZA
Essence
Сущность

FINITURA
Finish
Отделка

VERSIONE
Version
Версия

ACCESSORI
Accessories
Аксессуары

MANIGLIA
Handle
Ручка

TOULIPIER

LACCATO PENNELLATO EST.119 - INT.100
ANTICATURA A SPUGNA

BATTENTE

COPRIFILO BAROCCO DA 100

PRIMO IMPERO C11011
ORO

KIEV

Luxury - Luxury - РОСКОШНЫЕ

46 |



ESSENZA
Essence
Сущность

FINITURA
Finish
Отделка

VERSIONE
Version
Версия

ACCESSORI
Accessories
Аксессуары

MANIGLIA
Handle
Ручка

TOULIPIER

LACCATO PENNELLATO EST.112 - INT.100
ANTICATURA A SPUGNA

BATTENTE

CAPITELLO TIPO 2

NORDICA
OTTONE LUCIDO



FINITURA: LACCATO PENNELLATO
ESTERNO 112 - INTERNO 100 -
ANTICATURA A SPUGNA.
*Finish: brushed lacquered outside 112 -
inside 100 - Sponge antiquing.*
Отделка: лакировка и окраска
снаружи 112 - внутри 100 -
Антикатура губкой.



48

MOSCA

Luxury - Luxury - РОСКОШНЫЕ

| 49



ESSENZA
Essence
Сущность

FINITURA
Finish
Отделка

VERSIONE
Version
Версия

ACCESSORI
Accessories
Аксессуары

MANIGLIA
Handle
Ручка

TOULIPIER

LACCATO PENNELLATO EST.112 - INT.100
ANTICATURA A SPUGNA - FOGLIA ORO

BATTENTE

CAPITELLO TIPO 2

LUIGI XVI C05110
ORO

LUCREZIA

Luxury - Luxury - РОСКОШНЫЕ

50 |



ESSENZA
Essence
Сущность

FINITURA
Finish
Отделка

VERSIONE
Version
Версия

ACCESSORI
Accessories
Аксессуары

MANIGLIA
Handle
Ручка

TOULIPIER

LACCATO PENNELLATO - ESTERNO AVORIO I12
DOPPIO COLORE BUGNA AVORIO I09

BATTENTE

CAPITELLO TIPO 2

MANIERISMO C01215
ORO



FINITURA: LACCATO PENNELLATO -
ESTERNO AVORIO 112 DOPPIO COLORE
- BUGNA AVORIO 109.

*Finish: brushed lacquered - Ivory outside 112,
two colours, ivory boss 109.*

Отделка: лакировка и окраска - Снаружи
слоновая кость 112 двойной цвет филенки
слоновая кость 109.



BERLINO

Luxury - Luxury - РОСКОШНЫЕ

| 53



ESSENZA
Essence
Сущность

FINITURA
Finish
Отделка

VERSIONE
Version
Версия

ACCESSORI
Accessories
Аксессуары

MANIGLIA
Handle
Ручка

TOULIPIER

LACCATO PENNELLATO - INT.190 - EST.204
ANTICATURA A SPUGNA - FOGLIA ARGENTO

BATTENTE

COPRIFILO BAROCCO DA 100

PRIMO IMPERO C12512
ORO

CLEOPATRA

Luxury - Luxury - РОСКОШНЫЕ

54 |



ESSENZA
Essence
Сущность

FINITURA
Finish
Отделка

VERSIONE
Version
Версия

ACCESSORI
Accessories
Аксессуары

MANIGLIA
Handle
Ручка

TOULIPIER

LACCATO PENNELLATO EST.109 - INT.112
FINITURA A CERA - FOGLIA ORO

BATTENTE

GINEVRA
OTTONE LUCIDO



FINITURA: LACCATO
PENNELATO ESTERNO 109 -
INTERNO 112 - FINITURA A CERA
- FOGLIA ORO.

*Finish: brushed lacquered outside 109 -
inside 112 - Wax finish - Golden leaf.*

Отделка: лакировка и окраска
снаружи 109 - внутри 112 - Отделка
воском - Фольгирование золотом.

INTARSIE

Inlays - ИНКРУСТИРОВАННЫЕ

56 |

LA GENTILEZZA DEL LEGNO tagliato in modo da combaciare perfettamente, fino ad ottenere disegni che arrivano ad una notevole complessità virtuosistica. Intarsi in legno pregiato che delineano una raffinatezza flessibile che accoglie e avvolge.

THE SOFT LOOKS OF WOOD that has been cut to perfectly fit in to create notably complex designs. Fine wooden inlays that outline welcoming and enveloping flexible sophistication.

ДЕЛИКАТНОСТЬ ДЕРЕВА, отличающегося специальной резьбой, создающей идеальную гармонию, вплоть до рисунков виртуозной сложности. Инкрустации из ценного дерева, которые очерчивают гибкую тонкость, приветливую и обволакивающую.







BOHEME

Intarsie - Inlays - ИНКРУСТИРОВАННЫЕ

| 59



ESSENZA
Essence
Сущность

FINITURA
Finish
Отделка

VERSIONE
Version
Версия

ACCESSORI
Accessories
Аксессуары

MANIGLIA
Handle
Ручка

LENGA - INTARSI IN ACERO

NOCE CHIARO

BATTENTE

COPRIFILO BOMBATO

BALTIC
OTTONE SATINATO

AIDA

Intarsie - Inlays - ИНКРУСТИРОВАННЫЕ

60 |



ESSENZA
Essence
Сущность

FINITURA
Finish
Отделка

VERSIONE
Version
Версия

ACCESSORI
Accessories
Аксессуары

MANIGLIA
Handle
Ручка

LENGA - INTARSI IN ACERO

NOCE CHIARO

BATTENTE

-

N.D.



ESSENZA IN LENGA E INTARSI IN ACERO, FINITURA NOCE CHIARO.
Lenga essence and maple inlays, light walnut finish.
Древесина ленга с кленовыми вставками, отделка светлый орех.



TOSCA

Intarsie - Inlays - ИНКРУСТИРОВАННЫЕ

| 63



ESSENZA
Essence
Сущность

FINITURA
Finish
Отделка

VERSIONE
Version
Версия

ACCESSORI
Accessories
Аксессуары

MANIGLIA
Handle
Ручка

LENGA - INTARSI IN ACERO

NOCE CHIARO

BATTENTE

COPRIFILO BOMBATO

PRIMO IMPERO C11011
ORO

ANTICATE

Distressed - С ЭФФЕКТОМ АНТИКАТУРЫ

64 |

ESISTONO POCCHI MATERIALI che con il tempo guadagnano di bellezza - il legno è uno di questi. È dalla voglia di raccontare la propria storia di vita a chi si riconosce come simile, per sensibilità artistica e rispetto per la natura che nascono queste porte. Così un casale o una vecchia masseria acquisisce subito lo splendore che gli compete.

THERE ARE FEW MATERIALS that become even more beautiful over time - wood is one of them. These doors stand out for the desire to portray the life of those who can relate to them for their artistic sensitivity and environmentally-friendly approach. So a farmhouse or an old manor farm immediately regain their glory.

НЕМНОГИЕ МАТЕРИАЛЫ с течением времени становятся краше - дерево является одним из них. Это от желания рассказать свою жизненную историю тем, кто признает себя похожим, ради художественной признательности и уважения к природе, из которых рождаются эти двери. Так сельский дом или старая ферма сразу приобретает блеск, которого она заслуживает.







GIOCONDA

Anticate - Distressed - С ЭФФЕКТОМ АНТИКАТУРЫ

| 67



ESSENZA
Essence
Сущность

TOULIPIER

FINITURA
Finish
Отделка

LACCATO AVORIO
PATINATO SFUMATO

VERSIONE
Version
Версия

BATTENTE

ACCESSORI
Accessories
Аксессуары

-

MANIGLIA
Handle
Ручка

RITA
ARGENTO VECCHIO

CASALE

Anticate - Distressed - С ЭФФЕКТОМ АНТИКАТУРЫ

68 |



ESSENZA
Essence
Сущность

FINITURA
Finish
Отделка

VERSIONE
Version
Версия

ACCESSORI
Accessories
Аксессуары

MANIGLIA
Handle
Ручка

FRASSINO

DECAPATO ANTICATO
BORDI ROSSI

BATTENTE
BUGNE A CAPPELLO DI PRETE

COPRIFILO BAROCCO DA 100

N.D.





FINITURA: AVORIO 107
STRACCIATO - DOPPIO COLORE
VERDE ANTICO SU BUGNA.
*Finish: ivory 107 distressed - two
colours, antique green boss.*
Отделка: слоновая кость 107
изношенный - двойной цвет
зеленый, состаренный на
филенке.

CASALE V

Anticate - Distressed - с ЭФФЕКТОМ АНТИКАТУРЫ

| 71



ESSENZA
Essence
Сущность

FINITURA
Finish
Отделка

VERSIONE
Version
Версия

ACCESSORI
Accessories
Аксессуары

MANIGLIA
Handle
Ручка

FRASSINO

AVORIO 107 STRACCIATO
DOPPIO COLORE VERDE ANTICO SU BUGNA

BATTENTE

CAPITELLO TIPO 2

ROMEA
OTTONE ANTICATO



CASALE

Anticate - Distressed - с ЭФФЕКТОМ АНТИКАТУРЫ

| 73



ESSENZA
Essence
Сущность

CASTAGNO

FINITURA
Finish
Отделка

NOCE MEDIO/A ANTICATO

VERSIONE
Version
Версия

BATTENTE

ACCESSORI
Accessories
Аксессуары

CAPITELLO TIPO 2

MANIGLIA
Handle
Ручка

N.D.

CASALE S

Anticate - Distressed - С ЭФФЕКТОМ АНТИКАТУРЫ

74 |



ESSENZA
Essence
Сущность

FINITURA
Finish
Отделка

VERSIONE
Version
Версия

ACCESSORI
Accessories
Аксессуары

MANIGLIA
Handle
Ручка

CASTAGNO

SABBIATO NOCE SCURO A CERA

BATTENTE

GINEVRA
BRONZO GRAFFIATO

CASALE 4V

Anticate - Distressed - С ЭФФЕКТОМ АНТИКАТУРЫ

| 75



ESSENZA
Essence
Сущность

FINITURA
Finish
Отделка

VERSIONE
Version
Версия

ACCESSORI
Accessories
Аксессуары

MANIGLIA
Handle
Ручка

CASTAGNO

SABBIATO NOCE CHIARO A CERA

BATTENTE

VETRO DVK CHIARO - COPRIFILI
TELESCOPICA 90°-INC.ROMBO

N.D.



ANTIQUA

Anticate - Distressed - С ЭФФЕКТОМ АНТИКАТУРЫ

| 77



ESSENZA
Essence
Сущность

FRASSINO

FINITURA
Finish
Отделка

NATURALE ANTICATA
PIALLATA A MANO

VERSIONE
Version
Версия

BATTENTE

ACCESSORI
Accessories
Аксессуары

-

MANIGLIA
Handle
Ручка

RITA
ARGENTO VECCHIO

CLASSICHE

Classical - КЛАССИЧЕСКИЕ

78 |

LA CASA, LUOGO DELL'ABITARE, rifugio affettivo. La casa e il suo stile raccontati attraverso la scelta delle porte. Un lungo tragitto estetico per ritornare a quella classicità che ci appartiene e per esprimere quello che siamo. L'estetica che caratterizza una CLASSICA Anselmi ha fissato nuovi canoni, diventando esempio per molti.

THE HOUSE, A LIVING SPACE, an emotional refuge. The house and its style portrayed through the choice of doors. A long aesthetic itinerary to go back to our classical nature and express who we are. The aesthetics for which a CLASSIC door by Anselmi stands out has set new standards, thereby becoming a model for many.

ДОМ, МЕСТО ЖИТЕЛЬСТВА, аффективное пристанище. Дом и его стиль, описанные выбором дверей. Долгий эстетический путь, чтобы вернуться к той, принадлежащей нам, классике и чтобы выразить себя. Эстетика, которая характеризует КЛАССИКУ Anselmi, установила новые стандарты, став примером для многих.





80 |



CASALE V

Classiche - Classical - КЛАССИЧЕСКИЕ

| 81



ESSENZA
Essence
Сущность

ROVERE

FINITURA
Finish
Отделка

NOCE MEDIO/A

VERSIONE
Version
Версия

DUE ANTE
TUTTO SESTO

ACCESSORI
Accessories
Аксессуары

CAPITELLI CON COPRIFILI UNGHIATI
VETRO SATINATO
MOLATURA TRASPARENTE

MANIGLIA
Handle
Ручка

MANIERISMO C01210
ORO



82

ARES

Classiche - Classical - КЛАССИЧЕСКИЕ

| 83

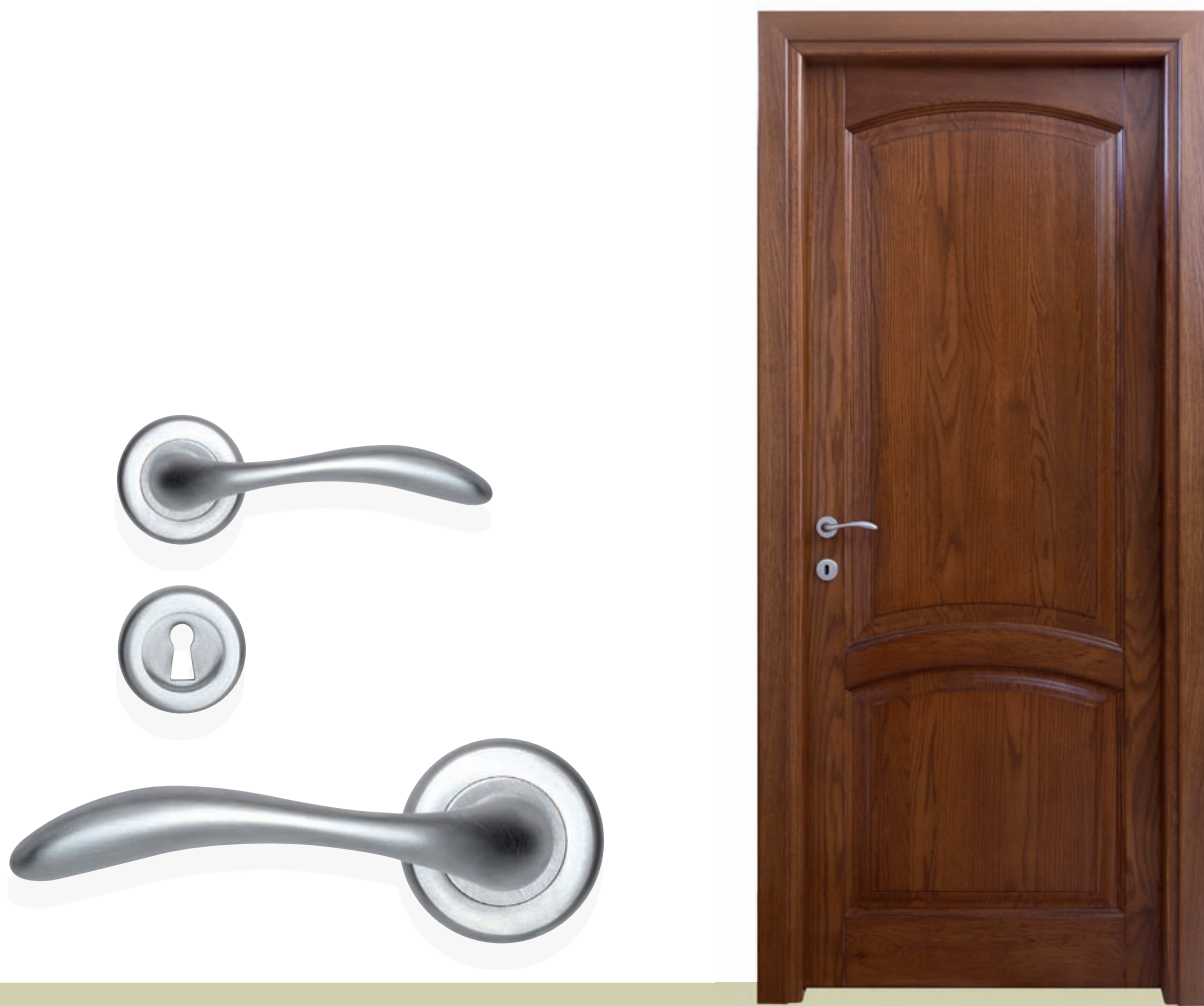

ESSENZA
Essence
Сущность

ROVERE

FINITURA
Finish
Отделка

NOCE CHIARO

VERSIONE
Version
Версия

BATTENTE

ACCESSORI
Accessories
Аксессуары

-

MANIGLIA
Handle
Ручка

LORY
CROMO SATINATO

MINERVA

Classiche - Classical - КЛАССИЧЕСКИЕ

84 |



ESSENZA
Essence
Сущность

TOULIPIER

FINITURA
Finish
Отделка

NOCE MEDIO/B

VERSIONE
Version
Версия

BATTENTE

ACCESSORI
Accessories
Аксессуары

COPRIFILO TELESCOPICO A 90°
VETRO 6/7 SATIN. CON DOPPIO RIGO
SABBIATURA E FORMELLA

MANIGLIA
Handle
Ручка

N.D.

APOLLO

Classiche - Classical - КЛАССИЧЕСКИЕ

| 85



ESSENZA
Essence
Сущность

TOULIPIER

FINITURA
Finish
Отделка

NOCE MEDIO/B

VERSIONE
Version
Версия

BATTENTE

ACCESSORI
Accessories
Аксессуары

-

MANIGLIA
Handle
Ручка

N.D.



ZEUS

Classiche - Classical - КЛАССИЧЕСКИЕ

| 87



ESSENZA
Essence
Сущность

TOULIPIER

FINITURA
Finish
Отделка

NOCE SCURO

VERSIONE
Version
Версия

BATTENTE

ACCESSORI
Accessories
Аксессуары

-

MANIGLIA
Handle
Ручка

LORY
OTTONE LUCIDO



GIOCONDA

Classiche - Classical - КЛАССИЧЕСКИЕ

| 89



ESSENZA
Essence
Сущность

TOULIPIER

FINITURA
Finish
Отделка

NOCE SCURO

VERSIONE
Version
Версия

BATTENTE

ACCESSORI
Accessories
Аксессуары

-

MANIGLIA
Handle
Ручка

LORY
CROMO SATINATO

PINTURICCHIO

Classiche - Classical - КЛАССИЧЕСКИЕ

90 |



ESSENZA
Essence
Сущность

FINITURA
Finish
Отделка

VERSIONE
Version
Версия

ACCESSORI
Accessories
Аксессуары

MANIGLIA
Handle
Ручка

TOULIPIER

NOCE CHIARO

BATTENTE

CAPITELLO TIPO 1

N.D.

ERMES

Classiche - Classical - КЛАССИЧЕСКИЕ

| 91



ESSENZA
Essence
Сущность

FINITURA
Finish
Отделка

VERSIONE
Version
Версия

ACCESSORI
Accessories
Аксессуары

MANIGLIA
Handle
Ручка

TOULIPIER

MEDIOVA

BATTENTE

-

N.D.



AFRODITE-R

Classiche - Classical - КЛАССИЧЕСКИЕ

| 93



ESSENZA
Essence
Сущность

FRASSINO

FINITURA
Finish
Отделка

NOCE MEDIO/A SFUMATO

VERSIONE
Version
Версия

DUE ANTE

ACCESSORI
Accessories
Аксессуары

VETRO RILEGATO A PIOMBO
CON GRISAGLIA DIPINTA A MANO

MANIGLIA
Handle
Ручка

LORY
OTTONE LUCIDO



ZEUS

Classiche - Classical - КЛАССИЧЕСКИЕ

| 95



ESSENZA
Essence
Сущность

TOULIPIER

FINITURA
Finish
Отделка

NOCE MEDIO/B

VERSIONE
Version
Версия

LIBRO

ACCESSORI
Accessories
Аксессуары

-

MANIGLIA
Handle
Ручка

-

MODERNE

Modern - СОВРЕМЕННЫЕ

96 |

UN PROGETTO PORTA assolutamente contemporaneo che ammicca talvolta ai modelli classici in una rilettura di chiaro stampo moderno. Il design si fa più lineare, un gioco di forme e materiali, l'assolutezza del legno e la laccatura si mescolano e si fondono in un UNICO prodotto.

A DOOR PROJECT with a strong contemporary feel that sometimes contains features of classical models with a clear modern reinterpretation. Design becomes more linear, a combination of shapes and materials. Wood's absolute nature and lacquering are mixed and blended together in just ONE product.

ПРОЕКТ ДВЕРИ, совершенно современный, который периодически перекликается с классическими моделями, но преобразует их, сохраняя четкие современные формы. Дизайн становится более линейным, игра форм и материалов, абсолютность дерева и лака смешиваются и сливаются в ЕДИНЫЙ продукт.







ATENA

Moderne - Modern - СОВРЕМЕННЫЕ

| 99

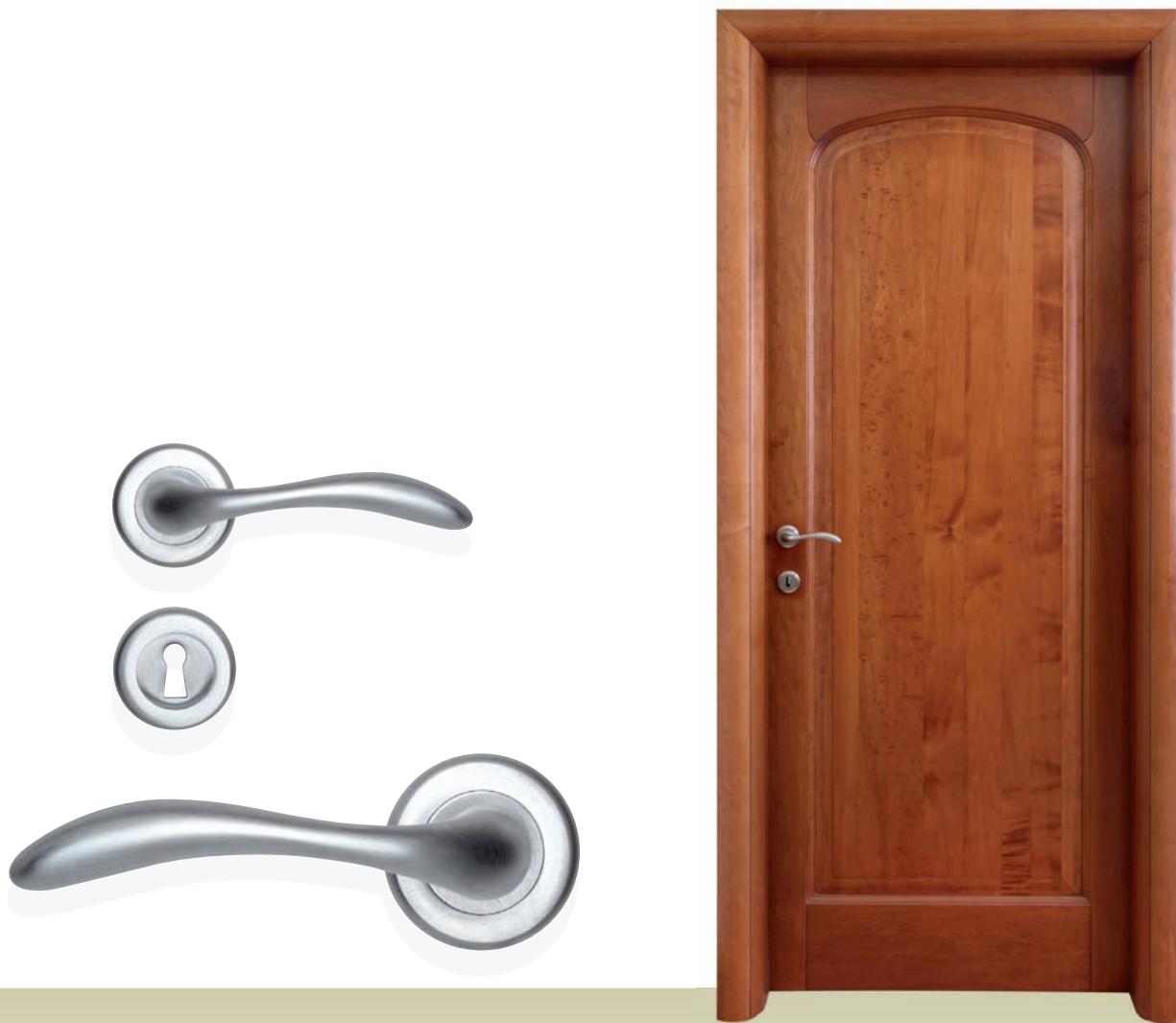

ESSENZA
Essence
Сущность

FINITURA
Finish
Отделка

VERSIONE
Version
Версия

ACCESSORI
Accessories
Аксессуары

MANIGLIA
Handle
Ручка

LENGA

CILIEGIO

BATTENTE

TELAIO E COPRIFILO
BOMBATO

LORY
CROMO SATINATO

100

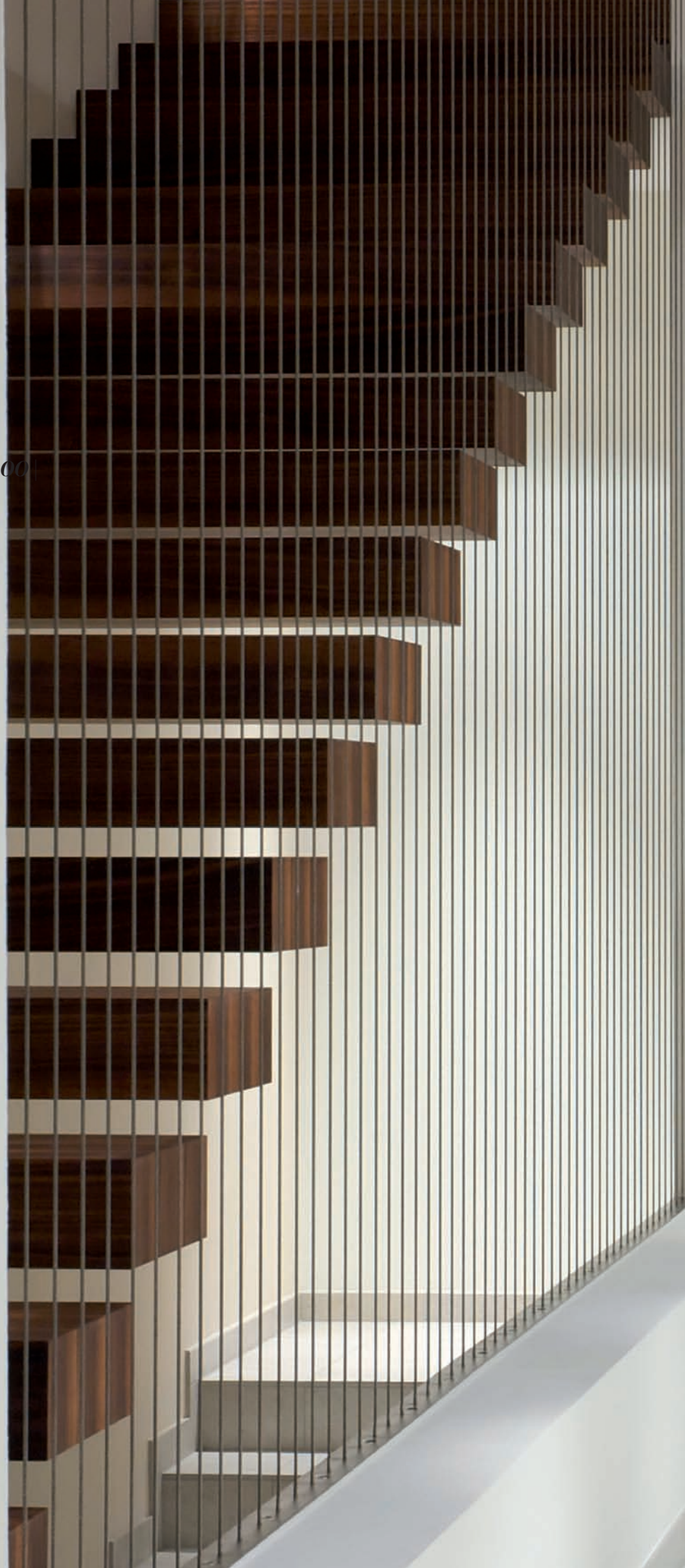

PICASSO

Moderne - Modern - СОВРЕМЕННЫЕ

| 101



ESSENZA
Essence
Сущность

FINITURA
Finish
Отделка

VERSIONE
Version
Версия

ACCESSORI
Accessories
Аксессуары

MANIGLIA
Handle
Ручка

LENGA

MIELE

BATTENTE

TELAJ E COPRIFILI BOMBATI
INCISIONE GIGLIO SU BUGNA

COMBY
CROMO LUCIDO + SATINATO

ATENA-S

Moderne - Modern - СОВРЕМЕННЫЕ

102 |



ESSENZA
Essence
Сущность

FINITURA
Finish
Отделка

VERSIONE
Version
Версия

ACCESSORI
Accessories
Аксессуары

MANIGLIA
Handle
Ручка

FRASSINO

SBIANCATO

BATTENTE

TELAJ E COPRIFILI BOMBATI

LORY
CROMO SATINATO

MICHELANGELO

Moderne - Modern - СОВРЕМЕННЫЕ

| 103



ESSENZA
Essence
Сущность

FRASSINO

FINITURA
Finish
Отделка

DECAPATO BIANCO
VENE NOCCIOLA

VERSIONE
Version
Версия

BATTENTE

ACCESSORI
Accessories
Аксессуары

TELA E COPRIFILI BOMBATI

MANIGLIA
Handle
Ручка

COMBY
CROMO LUCIDO + SATINATO

104 |



DIANA VETRO

Moderne - Modern - СОВРЕМЕННЫЕ

| 105



ESSENZA
Essence
Сущность

FRASSINO

FINITURA
Finish
Отделка

LACCATO BIANCO A PORO APERTO

VERSIONE
Version
Версия

BATTENTE

ACCESSORI
Accessories
Аксессуары

COPRIFILI TELESCOPICI DRITTI
BOMBATI - TRAVERSA PIATTA
VETRO 6/7 SATIN. CON FORMELLE BLU 15

MANIGLIA
Handle
Ручка

LORY
CROMO SATINATO

RAFFAELLO

Moderne - Modern - СОВРЕМЕННЫЕ

106 |



ESSENZA
Essence
Сущность

FINITURA
Finish
Отделка

VERSIONE
Version
Версия

ACCESSORI
Accessories
Аксессуары

MANIGLIA
Handle
Ручка

TOULIPIER

NOCE MEDIO/B

BATTENTE

TELA E COPRIFILI BOMBATI

N.D.

VENERE

Moderne - Modern - СОВРЕМЕННЫЕ

| 107



ESSENZA
Essence
Сущность

FRASSINO

FINITURA
Finish
Отделка

WENGÈ

VERSIONE
Version
Версия

BATTENTE

ACCESSORI
Accessories
Аксессуары

TELAJ E COPRIFILI BOMBATI

MANIGLIA
Handle
Ручка

COMBY
CROMO LUCIDO + SATINATO



ATENA

Moderne - Modern - СОВРЕМЕННЫЕ

| 109



ESSENZA
Essence
Сущность

FRASSINO

FINITURA
Finish
Отделка

DECAPATO TORTORA 177
CON VENE BIANCHE

VERSIONE
Version
Версия

BATTENTE

ACCESSORI
Accessories
Аксессуары

TELA E COPRIFILI BOMBATI

MANIGLIA
Handle
Ручка

BALTIC
CROMO SATINATO

ACCESSORI

Accessories - ДЕТАЛИ

110 |

PER CONCLUDERE UN PERCORSO STILISTICO nasce la collaborazione con due tra le aziende italiane creatrici di preziosi oggetti di maniglie per porte e accessori come Cassina e Reguitti. Oggetti di una bellezza senza tempo. Quando tre eccellenze si incontrano vanno a formare un connubio perfetto che esprime stile ed eleganza.

THE PARTNERSHIP WITH TWO ITALIAN COMPANIES MAKING precious handles for doors and accessories, Cassina and Reguitti, stems from the desire TO COMPLETE A STYLISTIC PATH. Items of timeless beauty. When three top companies come together, they form a perfect combination expressing style and elegance.

ЧТОБЫ ЗАВЕРШИТЬ СТИЛИСТИЧЕСКИЙ ПУТЬ, рождается сотрудничество двух креативных итальянских компаний, которые создают драгоценные дверные ручки и аксессуары, таких как Cassina и Reguitti. Предметы вечной красоты. Когда встречаются три превосходства, они образуют идеальное сочетание, которое выражает стиль и элегантность.





MANIGLIE

Handle - Ручка

112 |



GINEVRA
Bronzo Graffiato - rosetta tipo "lusso"



GINEVRA
Ottone Lucido - rosetta tipo "lusso"



RITA
Argento Vecchio - rosetta con bordo e grano

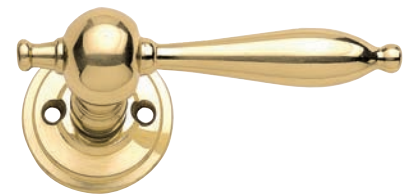

RITA
Ottone Lucido - rosetta con bordo e grano



CINZIA (Decoro B)
Ottone Anticato - rosetta con bordo e grano



CINZIA (Decoro C)
Ottone Anticato - rosetta con bordo e grano



CINZIA (Decoro H)
Ottone Anticato - rosetta con bordo e grano



BALTIC
Cromo Satinato - rosetta tipo "lusso"



BALTIC
Ottone Satinato - rosetta tipo "lusso"



NORDICA
Ottone Anticato - rosetta speciale



NORDICA
Ottone Lucido - rosetta speciale



LORY
Cromo Satinato - rosetta tipo "lusso"



LORY
Ottone Lucido - rosetta tipo "lusso"



SASHA
Ottone Lucido + Satinato - rosetta tipo "lusso"



SASHA
Cromo Lucido + Satinato - rosetta tipo "lusso"



ROMEIA
Ottone Rustico - rosetta tipo "lusso"



ROMEIA
Ottone Anticato - rosetta tipo "lusso"



ROMEIA
Argento Vecchio - rosetta tipo "lusso"



ROMEIA
Ottone Ruggine - rosetta tipo "lusso"



EPOCA
Argento Vecchio - rosetta tipo "lusso"



EPOCA
Ottone Anticato - rosetta tipo "lusso"



CHARME
Argento Vecchio - rosetta tipo "lusso"



CHARME
Ottone Anticato - rosetta tipo "lusso"



CHARME
Ottone Rustico - rosetta tipo "lusso"



COMBY
Cromo Lucido + Satinato - rosetta tipo "lusso"

MANIGLIE

Handles - Ручка

114 |



LUIGI XV cod. C01615
Cromo Satinato



LUIGI XV cod. C06710
Oro



LUIGI XV cod. C06715
Oro



LUIGI XV cod. C09110
Oro



LUIGI XV cod. C11910
Oro



LUIGI XV cod. C12810
Oro



LUIGI XVI cod. C05110
Oro



MANIERISMO cod. C01210
Oro



MANIERISMO cod. C01215
Cromo Satinato



MANIERISMO cod. C01215
Oro



MOONCHARME MADREPERLA
cod. C03011 - Nickel Nero



MOONCHARME MADREPERLA
cod. C03011 - Oro



MOONCHARME SWAROVSKY
cod. C0301L_SW - Nickel Nero



MOONCHARME SWAROVSKY
cod. C0301L_SW - Oro



PRIMO IMPERO cod. C05011
Oro



PRIMO IMPERO cod. C08311
Oro



PRIMO IMPERO cod. C11011
Oro



PRIMO IMPERO cod. C12511
Oro



PRIMO IMPERO cod. C12512
Oro



PRIMO IMPERO cod. C12512
Cromo Satinato



SECONDO IMPERO cod. C08710
Oro



SECONDO IMPERO cod. C08711
Oro



STILE 900 cod. C12611
Cromo

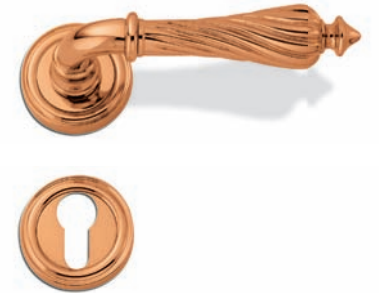

STILE 900 cod. C12611
Rame



VITTORIANO cod. C12110
Cromo Satinato



VITTORIANO cod. C12110
Oro



VITTORIANO cod. C12111
Bronzo



VITTORIANO cod. C12111
Oro

ACCESSORI

Accessories - Детали

116 |

Chiavi - Keys - Ключи



LUIGI XV cod. C54000
Oro



LUIGI XV cod. C54600
Bronzo Antico



PRIMO IMPERO
cod. C54700 - Oro



PRIMO IMPERO
cod. C54800 - Oro



PRIMO IMPERO
cod. C54900 - Oro

Nottolino libero/occupato - *Looks free/locked* - Открытие бесплатно/занято



LUIGI XV cod. CB5180
Oro / Bronzo Antico



LUIGI XV cod. CB5245
Oro



PRIMO IMPERO
cod. CB5340 - Cromo Satinato



PRIMO IMPERO
cod. CB5340 - Oro



BAROCCO cod. CB5570
Oro



FERRAMENTA

Accessories - Детали

KIT SCORREVOLE completi di serratura, contropiastra, nottolini e ditale di trascinamento



Cromo Satinato



Ottone Lucido

| 117

Nottolino libero/occupato - Looks free/locked - Открытие бесплатно/занято



NOTTOLINO WC
Cromo Satinato



NOTTOLINO WC
Ottone Lucido



NOTTOLINO STANDARD
con perno centrale - Ottone Lucido



NOTTOLINO WC
Ottone Anticato



NOTTOLINO WC
cod. 512

Maniglie - Handles - Ручка



Maniglia ovale per
scorrevole senza serratura
Cromo Satinato/Ottone Lucido



Maniglia ovale per
scorrevole con serratura chiave
Cromo Satinato



Maniglia tonda per
scorrevole senza serratura
Bronzo Graffiato/Cromo Satinato/
Ottone Rustico



Maniglia tonda per scorrevole
con serratura chiave
Ottone Lucido/Cromo Satinato

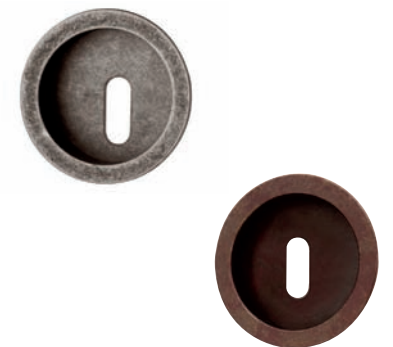

Maniglia tonda per scorrevole
con serratura chiave
Argento Vecchio/
Cromo Ottone Anticato

ESSENZE

Wood essences - Древесных пород

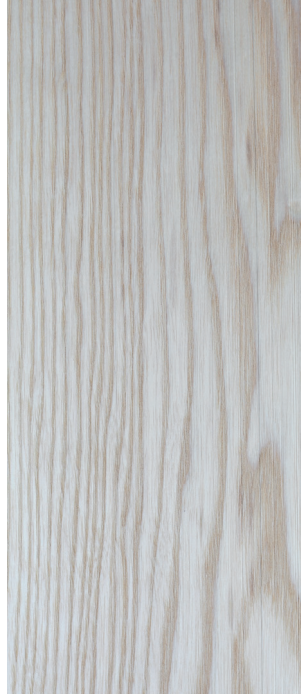

TOULIPIER

(Toulipier - Тюльпановое дерево)
Essendo un albero che cresce alto e dritto fornisce del legname che, con le sue caratteristiche di lavorabilità e stabilità lo rendono adatto ad un gran numero di impieghi. Ha colore biancastro, venatura evidente con fiammature scure o verdastre e consistenza tenera.

Being a tree that grows tall and straight provides timber that, with its workability and stability make it suitable for a large number of applications. It has whitish color, texture evident with flaming dark or greenish and tender consistency.

Высокое (до 30-35 м) дерево, обхват ствола у основания может составлять 10-15м. Это одним из самых благородных пород древесины. Произрастает на востоке Северной Америки, в некоторых областях Азии. Древесина тюльпанового дерева достаточно прочная, но в тоже время она ценится за свою мягкость в обработке, легкость и гибкость. Цвет светлого цвета с достаточно выраженными прожилками более темных или зеленоватых тонов.

FRASSINO

(Ash - Ясень)
Il legno di frassino è largamente utilizzato perché è robusto e nello stesso tempo leggero e flessibile. È molto usato sia per le sue caratteristiche tecniche che per l'aspetto. È un legno dalla colorazione abbastanza chiara che varia dal bianco grigiastro al marrone chiaro.

The ash wood is widely used because it is robust, same time light and flexible. It 'widely used both for its technical characteristics and appearance. The wood is quite clear. The colors varies from grayish white to light brown.

Очень широко используемый тип древесины. Рисунок древесины с ярко выраженным строением волокон. Заболонь (более наружные слои древесины) ясеня чаще всего светло-розового оттенка или желтого, а ядро светло-бурого, с коричневым оттенком. Древесина крепкая, прочная, обладает отличными механическими и физическими свойствами. Красивая текстура напоминает дуб. Превосходно обрабатывается.

LENGA

(Cherry - Вишня)
Diffuso nelle Ande meridionali tra Cile e Argentina, la sua colorazione va dal roseo al brucicco giallognolo che con l'essiccazione tende a scurire. È un legno gradevole con le fibre intrecciate o ondulate, facile da lavorare. Ha le venature simili a quelle del ciliegio americano.

Widespread in the southern Andes between Chile and Argentina, its color ranges from pink to brownish yellowish that by drying tends to darken. It is a pleasant wood with woven fibers or undulated, easy to work with. It has the veins similar to those of the cherry.

Распространена в южных Андах в регионах между Чили и Аргентиной. Цветовой диапазон колеблется от розоватого до желтовато-коричневого, при сушке древесина имеет тенденцию темнеть. Древесина очень декоративная, с несколько волнообразным рисунком волокон. Хорошо поддается обработке, отлично гнется и сохраняет стабильность размеров после камерной сушки. Обладает средними характеристиками прочности и устойчивости к ударным воздействиям.

ROVERE

(Oak - Ровере)
Il rovere è un legno molto pregiato, della famiglia delle quercie (*Quercus Petraea*). Le sue caratteristiche principali sono la durezza e la stabilità. Colore bruno giallastro.

*The oak wood is very fine, of the family of oaks (*Quercus Petraea*). Its main features are the hardness and stability. Yellowish brown color.*

Одно из самых престижных материалов для изготовления дверей. Преимущество древесины дуба - долговечность и стойкость к влаге. Именно поэтому массив дуба очень прочный, что однако вызывает трудности в обработке древесины и увеличивает трудоемкость изготовления продукции из этого материала. Древесина дуба имеет желтовато-коричневый оттенок, очень красивую текстуру. Своеобразный оттенок благородной старины свойственен древесине дуба, объясняется тем, что со временем она темнеет.

CASTAGNO

(Chestnut Tree - Каштан)
Il castagno è un legno europeo molto conosciuto ed utilizzato. È di colore bruno molto chiaro, è molto durevole e resistente all'umidità. Ha una venatura molto accentuata, adatta per ambienti antichi e rustici.

The chestnut is an european very popular and used wood. It has a light brown color, it's very durable and resistant to moisture. It has a very pronounced grain, suitable for environments antique and rustic.

Каштан – одно из самых известных используемых европейских пород дерева. Древесина каштана по строению и внешнему виду (текстуре) очень напоминает древесину дуба, каштан совсем немного уступает ему в прочности. Цвет светло-коричневый, пронизана блестящими жилками, что придает ей особый лоск. Древесина каштана способна отлично сохраняться в условиях высокой влажности, отличается высокой упругостью. А легкость ее обработки делает данный материал идеальным для создания полированных поверхностей.

PINO

(Pine - Сосна)
Legno europeo di colore bruno chiaro, tessitura media e fibratura dritta, caratterizzato da nodi. Legno leggero, ottima resistenza all'umidità e abbastanza durevole.

Widespread in the southern Andes between Chile and Argentina, its color ranges from pink to brownish yellowish that by drying tends to darken. It is a pleasant wood with woven fibers or undulated, easy to work with. It has the veins similar to those of the cherry.

Цвета массива сосны желтовато-коричневый, янтарный. На всех разрезах хорошо видно годовичные слои, характеризуется наличием «сучков». Она легко поддается обработке, шлифовке, имеет приятный натуральный тёплый оттенок и тонкий аромат. Благодаря современным способам обработки древесина не рассыхается, не поддается коррозии под действием влаги и сохраняет отличный внешний вид в течение всего срока эксплуатации.

FINITURE

Finishes - Отделка

120 |

Tinti Noce

» TOULPIER

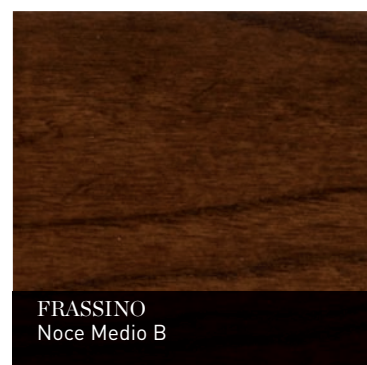
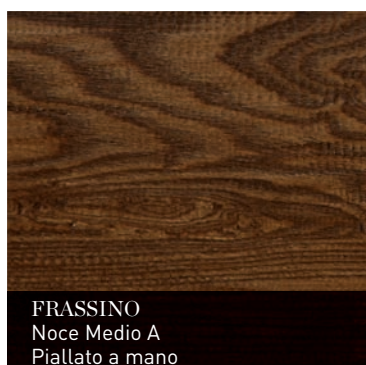
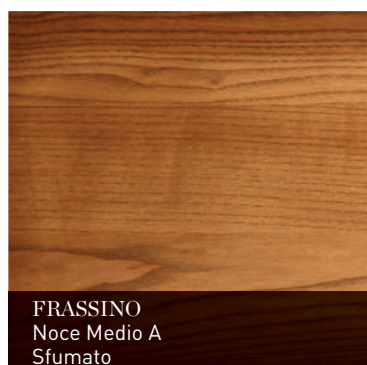
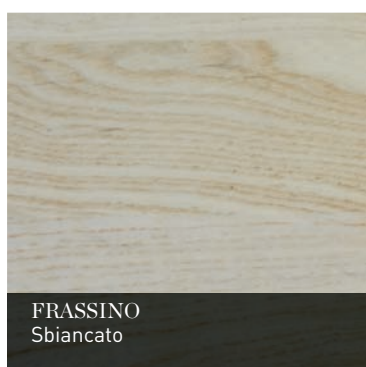
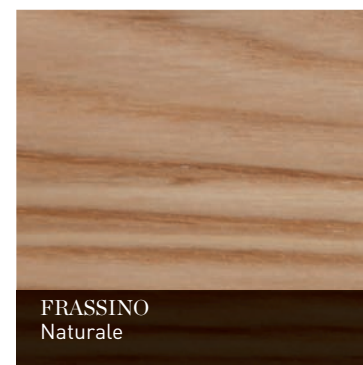
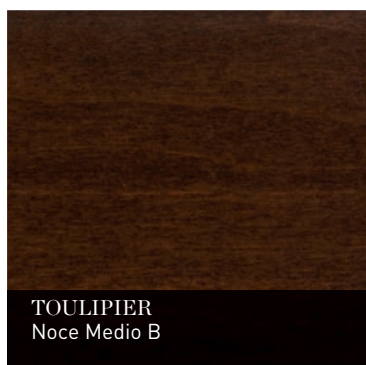
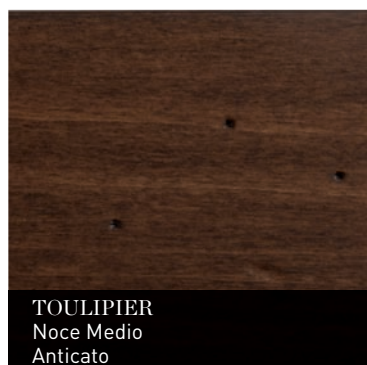
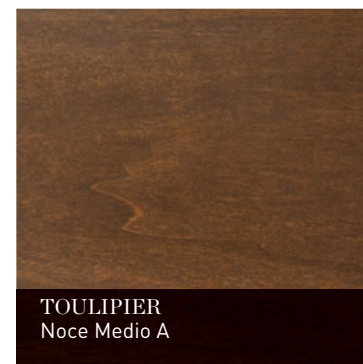
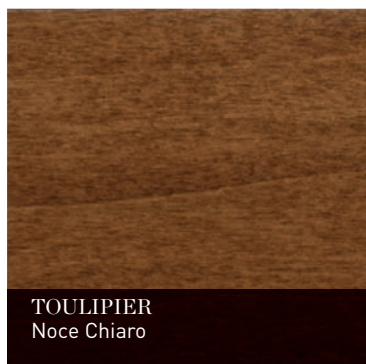

FINITURE

Finishes - Отделка

Tinti Noce

» ROVERE

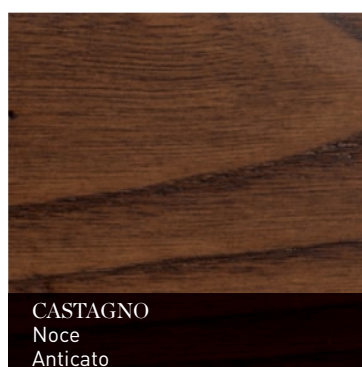
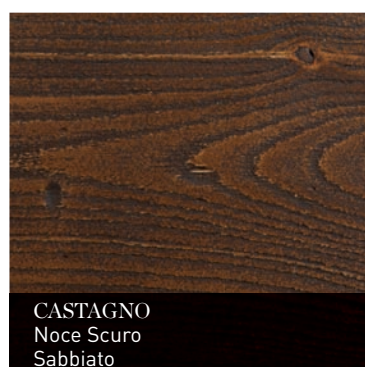
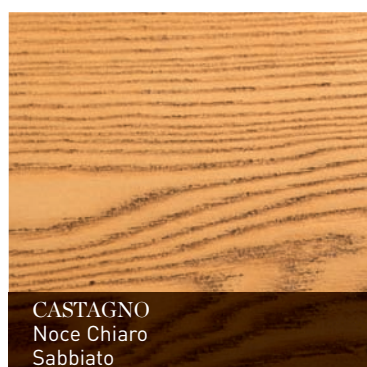
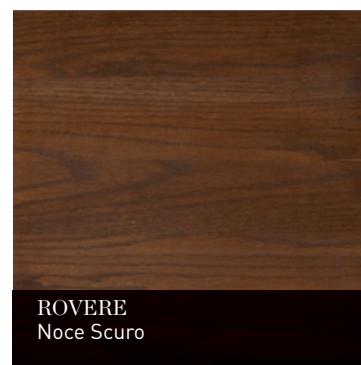
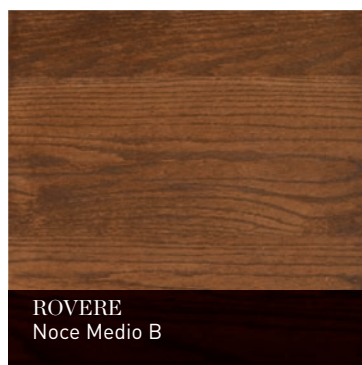
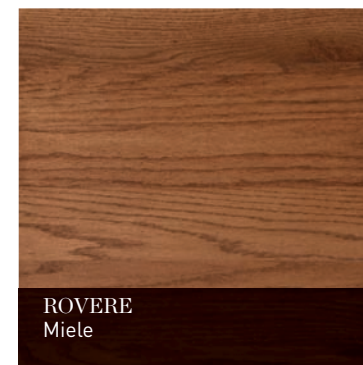
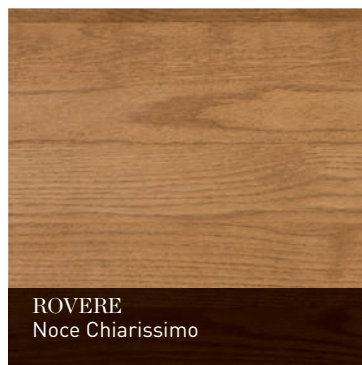
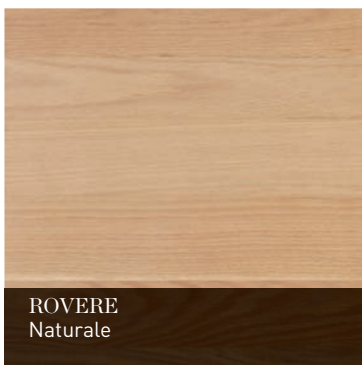

FINITURE

Finishes - Отделка

122 |

Laccati

» TOULIPIER



TOULIPIER
Bianco Sporco
Patinato



TOULIPIER
Avorio 109
Patinato



TOULIPIER
Bianco Antico



TOULIPIER
Crema 103 Antico

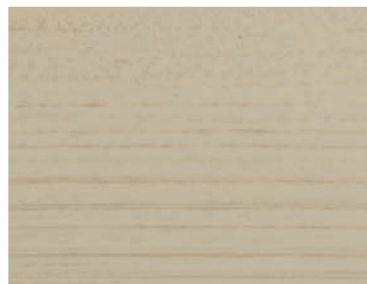

TOULIPIER
Panna 106
Pennellato Anticato



TOULIPIER
Avorio Caldo 111
Pennellato Anticato



TOULIPIER
Panna 106
Consumato Anticato

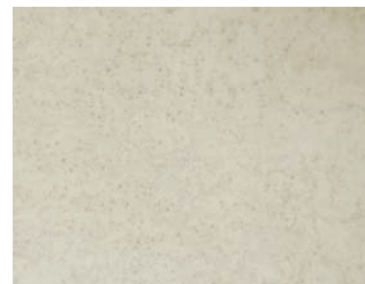

TOULIPIER
Laccato Anticato a spugna

Laccati

» FRASSINO



FRASSINO
Laccato a Poro Aperto



FRASSINO
Avorio 107 Antico

Decapati e Decapati Anticati

» FRASSINO



FRASSINO DECAPATO
Bianco
Vene Grigio Chiaro



FRASSINO DECAPATO
Bianco
Vene Nocciola



FRASSINO DECAPATO
Avorio Caldo 111
Vene Bianche

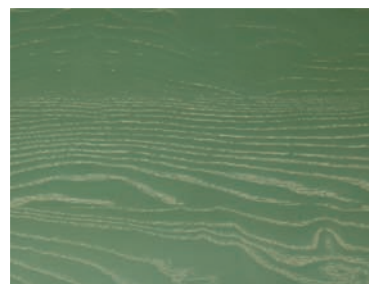

FRASSINO DECAPATO
Verde
Vene Oro

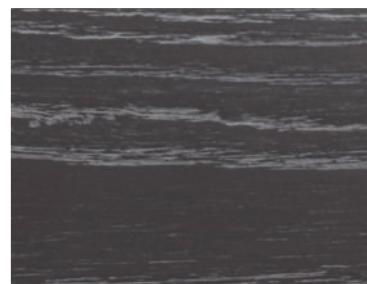

FRASSINO DECAPATO
Tortora 177
Vene Bianche



FRASSINO DECAPATO ANTICATO
Bianco Antico



FRASSINO DECAPATO ANTICATO
Decapato Anticato

FINITURE

Finishes - Отделка

SI ESEGUONO ANCHE FINITURE
SU CAMPIONE / WE ALSO
PERFORM FINISHING ON
SAMPLE / ТАКЖЕ ВЫПОЛНЯЕМ
ОТДЕЛОЧНЫЕ НА ОБРАЗЦЕ

| 123

Colori base per Laccati e Decapati

* Oltre ai presenti colori sono
disponibili tutti i colori della
mazzetta RAL / *In addition to
these colors are available in all
RAL colours* / В дополнение
к эти цвета доступны во
всех цветах RAL

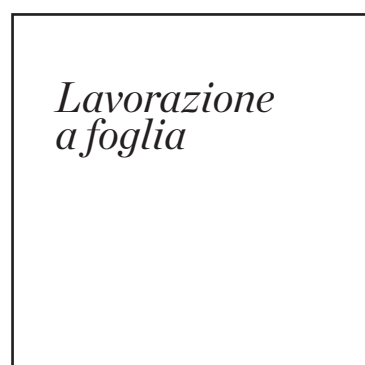
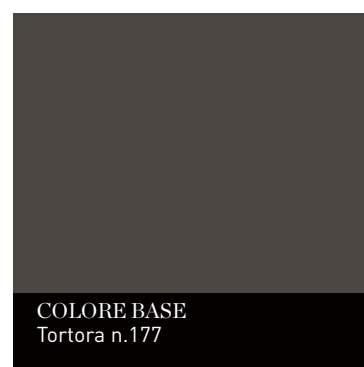

MODELLI PORTE

Door models - Модели дверей

124

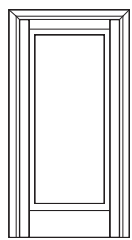

PICASSO

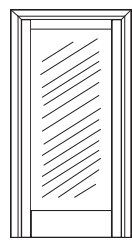

PICASSO
VETRO

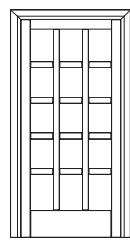

PICASSO
INGLESE

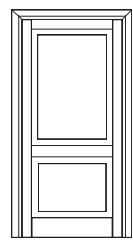

DONATELLO

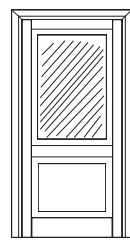

DONATELLO
VETRO

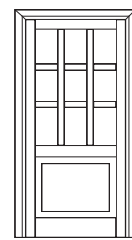

DONATELLO
INGLESE

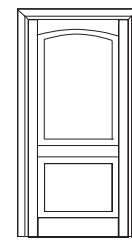

BRUNELLESCHI

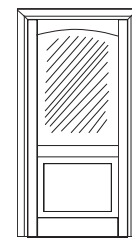

BRUNELLESCHI
VETRO

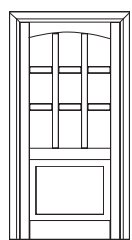

BRUNELLESCHI
INGLESE

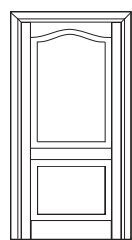

BERNINI

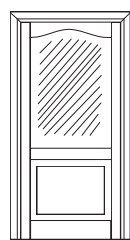

BERNINI
VETRO

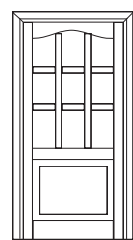

BERNINI
INGLESE

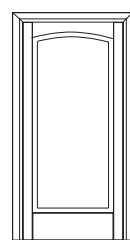

CIMABUE

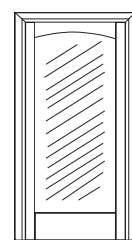

CIMABUE
VETRO

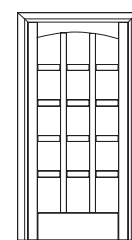

CIMABUE
INGLESE

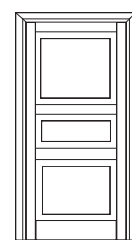

PINTURICCHIO

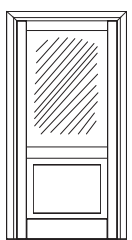

PINTURICCHIO
VETRO

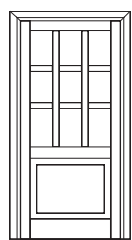

PINTURICCHIO
INGLESE

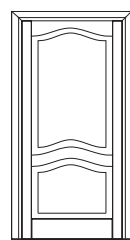

AFRODITE

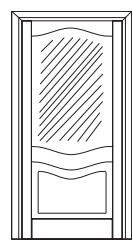

AFRODITE
VETRO

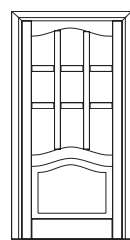

AFRODITE
INGLESE

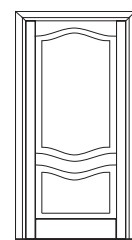

AFRODITE-R

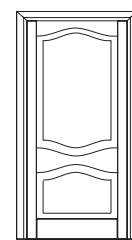

AFRODITE-3CP

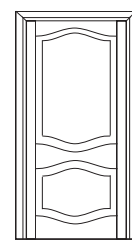

AFRODITE-4CP

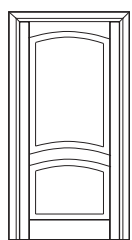

ARES

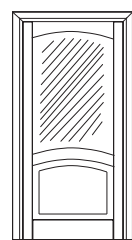

ARES
VETRO

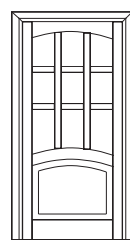

ARES
INGLESE

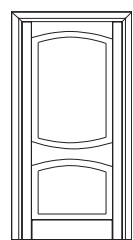

APOLLO

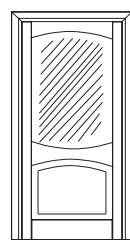

APOLLO
VETRO

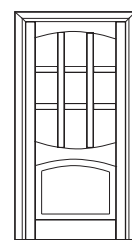

APOLLO
INGLESE

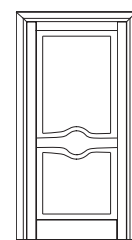

ERMES

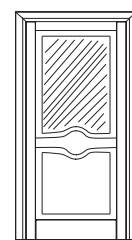

ERMES
VETRO

MODELLI PORTE

Door models - Модели дверей

| 125

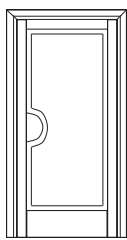

RAFFAELLO

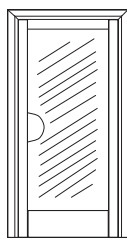

RAFFAELLO
VETRO

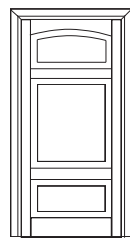

I VESPRI

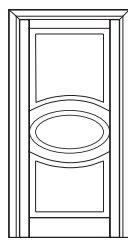

GIOCONDA

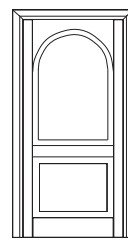

GIOTTO

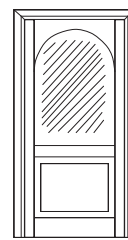

GIOTTO
VETRO

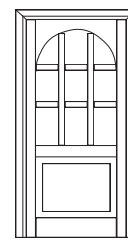

GIOTTO
INGLESE

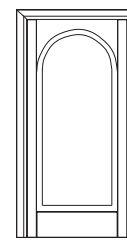

MICHELANGELO

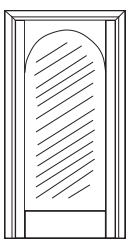

MICHELANGELO
VETRO

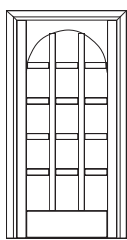

MICHELANGELO
INGLESE

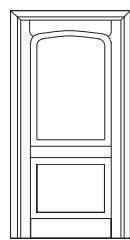

ZEUS

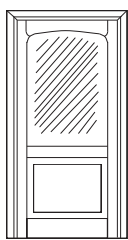

ZEUS
VETRO

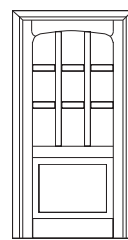

ZEUS
INGLESE

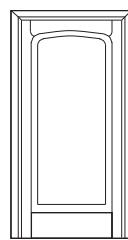

ATENA

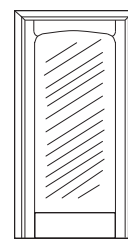

ATENA
VETRO

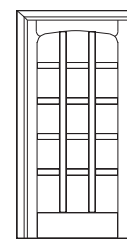

ATENA
INGLESE

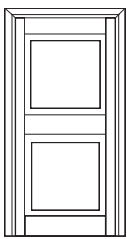

CASALE

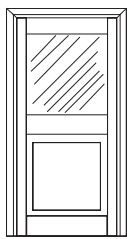

CASALE
VETRO

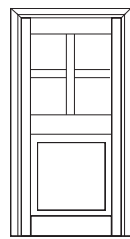

CASALE
4 VETRI

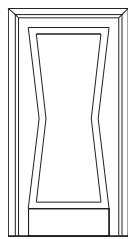

DIANA

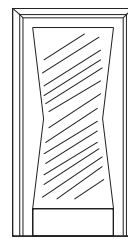

DIANA
VETRO

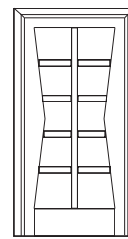

DIANA
INGLESE

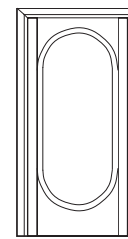

VENERE

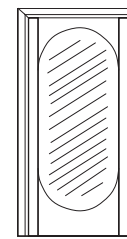

VENERE
VETRO

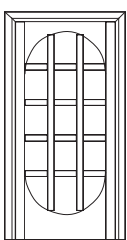

VENERE
INGLESE

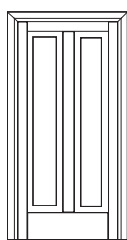

OTELLO

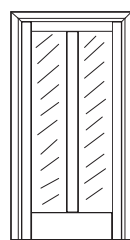

OTELLO
VETRO

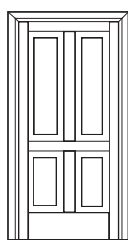

QUADRA

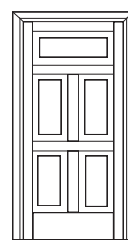

PENTAGONO

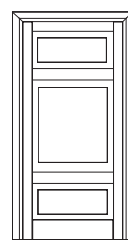

FRANCESCA

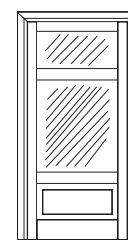

FRANCESCA
VETRO

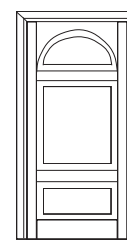

MINERVA

AREA TECNICA

Technical area - Технические области

Telai e Coprifili - Door frame and Cover-wires - Дверная рама и Проволоки освещение

TELAIO STANDARD

Standard Door Frame - Стандартная дверная коробка

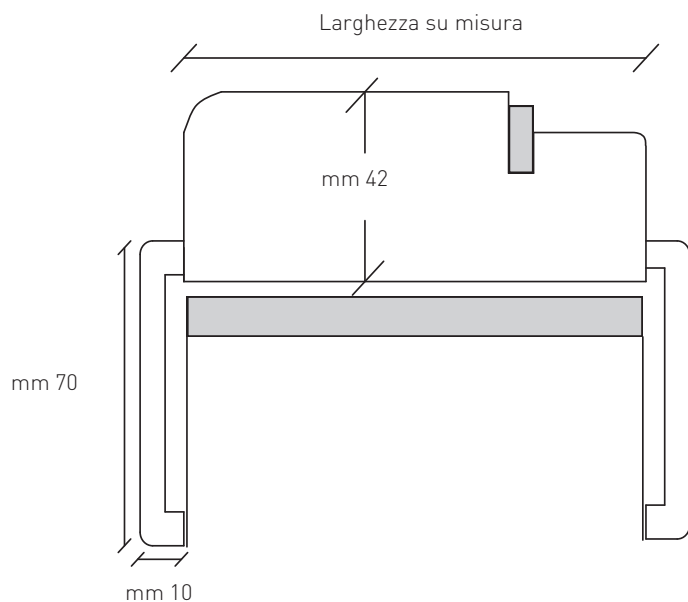

TELAIO BOMBATO

Convex Door Frame - Выпуклый дверная рама

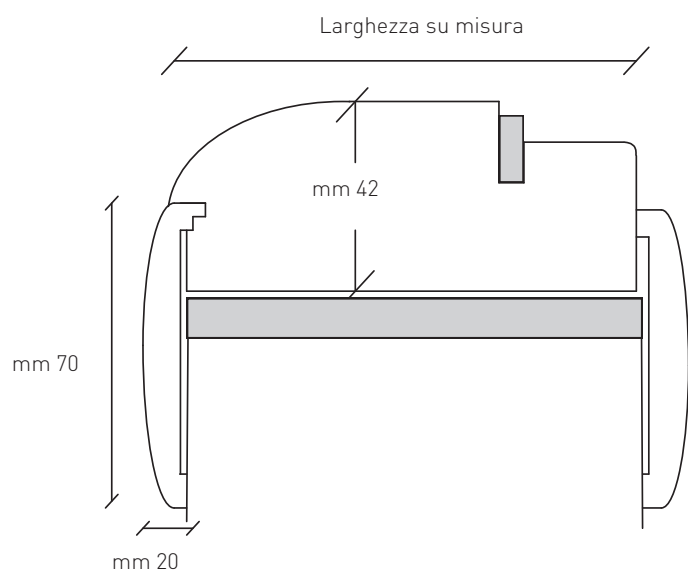

COPRIFILI

Cover-wires - Проволоки освещение

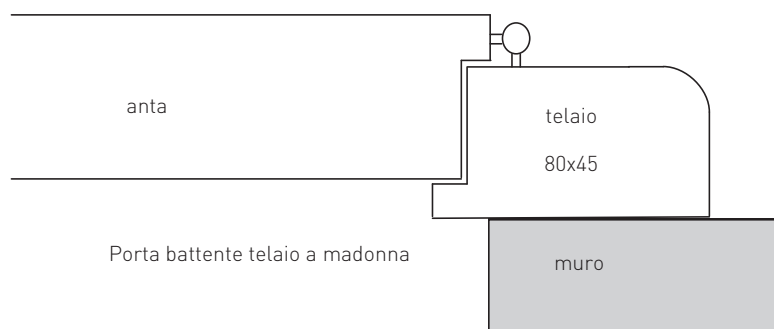
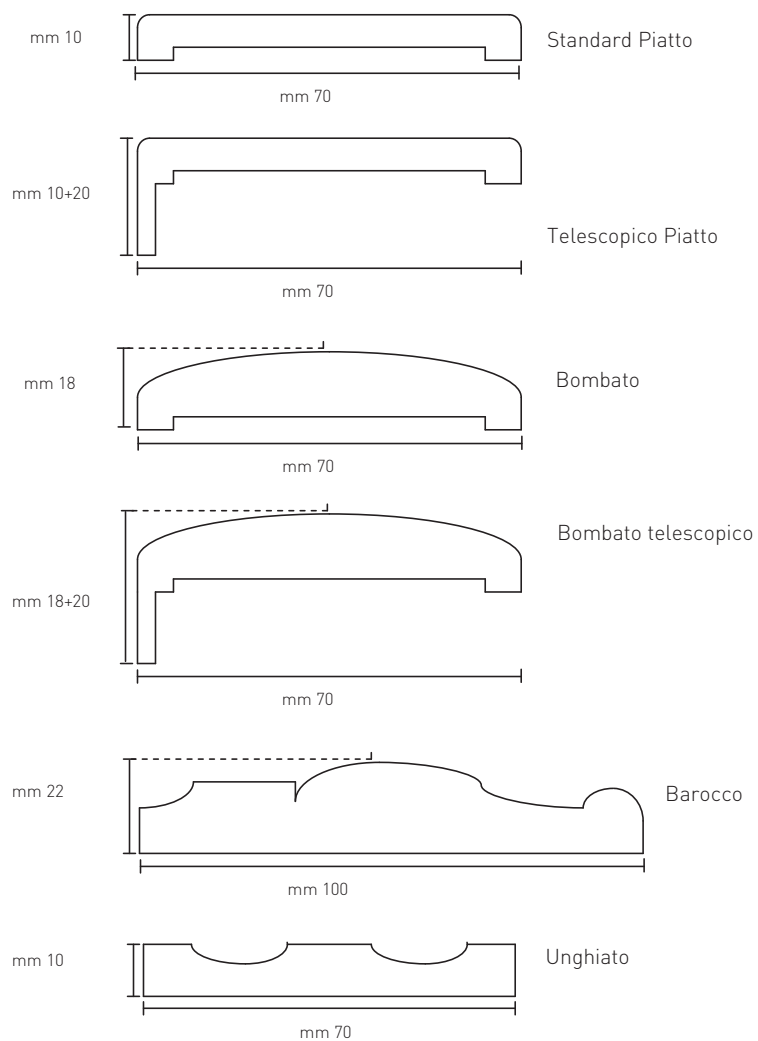

AREA TECNICA

Technical area - Технические области

Telai - Door frame - Дверная рама

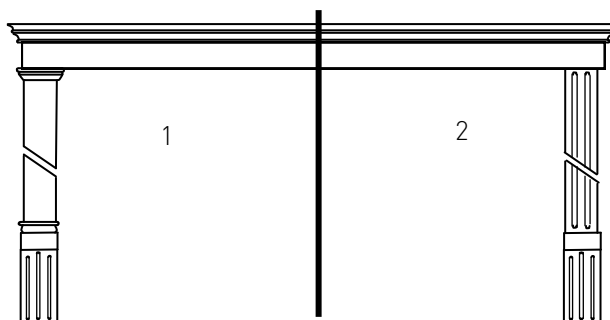

CAPITELLI Capitals - Столиц

- 1-Capitello classico completo di zoccoli e finali
- 2-Capitello con coprifilo unghiato e zoccolo

| 127

Pannelli - Panels - Панелей

VERSIONI DISPONIBILI Versions available - Доступные версии



Porta a battente

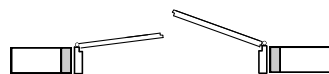

Porta due ante simmetriche

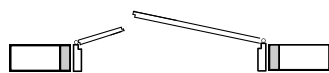

Porta due ante asimmetriche

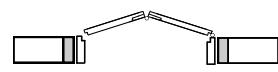

Porta a libro

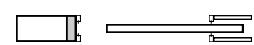

Porta scorrevole interno muro



Porta scorrevole esterno muro

TIPI DI PANNELLI Types of panels - Типы панелей

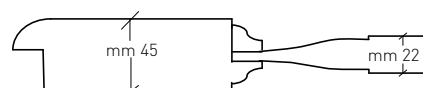

Pannello standard con bugna lavorata e regolino a "s"

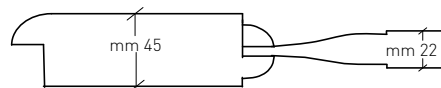

Pannello con bugna lavorata e regolino stondato

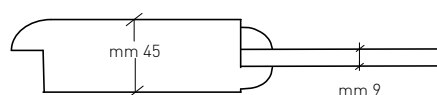

Tipo bugna liscia con regolino stondato

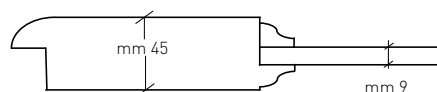

Tipo bugna liscia con regolino a "s"

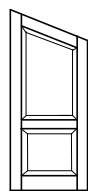

Porta Obliqua*

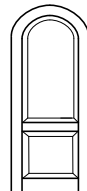

Porta ad arco*

*Versioni disponibili anche a due ante

VERSI DI APERTURA Opening verses - Дверь путь

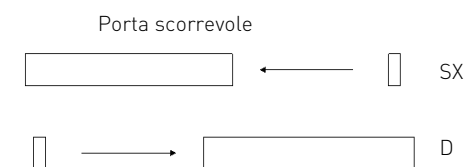
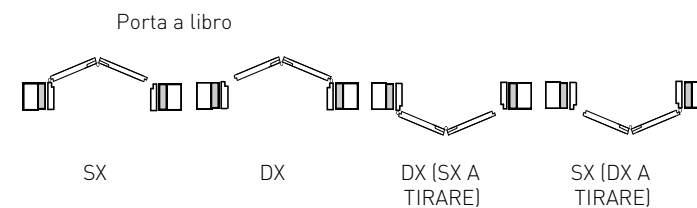
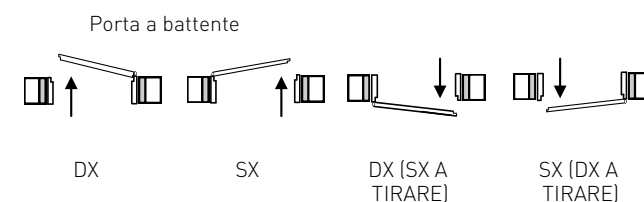

(I versi di apertura vanno sempre rilevati all'esterno della stanza)



Eventuali imperfezioni nelle finiture e nei materiali naturali, non sono da considerarsi difetti, ma caratteristica del prodotto per l'artigianalità della produzione.
La presente cartella colori ha valore puramente dimostrativo e indicativo.

Possible imperfections at the finishing and at the raw materials, are not defects, but features of the product due to the handmade production.
This colour has purely demonstrative and indicative value.

Любые недостатки в отделке и натуральных материалов, не должны быть рассмотрены дефектов, но особенностью продукта для мастерства производства.
Этот цвет имеет чисто демонстративной и ориентировочные значения.



ANSELMI
Sede: Località Maregnano snc
01039 Vignanello [Viterbo]
Italy

Filiale e Showroom: Via Luigi Abbiati, 13
25134 Brescia
Italy

T. +39 0761 755557 - 0761 586974
F. +39 0761 756128
Cell. +39 340 4065515

www.anselmiporte.it
info@anselmiporte.it